

Instruction Manual

Vibration Isolators

Description	Item Number
Vibration Isolators (Speedivac 2)	A248-01-403
Vibration Isolators (E1M/E2M2, 5, 8, 12 and 18)	A248-01-404
Vibration Isolators (E1M/E2M40 and 80)	A248-01-405
Vibration Isolators (E1M/E2M175 and 275)	A248-01-406
Vibration Isolators (E2M1 and E2M1.5)	A248-01-407
Vibration Isolators (E2M28)	A248-01-412
Vibration Isolators (DP180)	A248-01-414
Vibration Isolators (DP80)	A248-01-416

This page has been intentionally left blank.

Contents

Section	Page
1 Installation	1
2 Technical data	2
3 Transit	3
4 Dimensions	4

For return of equipment, complete the HS Forms at the end of this manual.

Illustrations

Figure	Page
1 Using Vibration Isolators during transit	3
2 Dimensions of Vibration isolator for Speedivac 2 pumps	4
3 Dimensions of vibration Isolators for E2M1.5 pumps	4
4 Dimensions of Vibration Isolator for E2M2, E1M5, E2M5, E1M8, E2M8, E2M12, E1M18, E2M18 and E2M28 pumps	5
5 Dimensions of Vibration Isolator for E1M40, E2M40, E1M80, E2M80 and DP80 pumps	5
6 Dimensions of Vibration Isolator for E1M175, E1M275, E2M275 and DP180 pumps	6

Tables

Table	Page
1 Check list of components	1
2 Technical data	2

This page has been intentionally left blank.

1 Installation

Check that your package contains the following items:

Table 1 - Check list of components

Qty	Description	Check(✓)
4	Vibration isolator	<input type="checkbox"/>
4	Pump fixing screw	<input type="checkbox"/>
4	Plain washer	<input type="checkbox"/>
4	Shakeproof washer	<input type="checkbox"/>

Note: Do not stack pumps on the top of each other if the maximum load per isolator stated in the Technical Data table will be exceeded.

If any of these items is missing, notify your supplier in writing in three days.

For Speedivac 2, E2M1.5, E2M2, E1M5, E2M5, E1M8, E2M8. E2M12 E1M18 and E2M18 pumps, remove the four rubber feet (if fitted), then fit the Vibration Isolators to the four mounting holes in the pump baseplate. On other pump fit the Vibration Isolators to the four mounting holes in the pump support skids.

All Vibration Isolators, with the exception of those for Speedivac 2 pumps, are suitable for free-standing. Alternatively, the Vibration Isolators have fixing holes for bolting to the floor or system frame, if required.

We recommend that you fit flexible tubing or bellows connections between the pump-inlet and pump-outlet and the rest of the system, to prevent the transmission of stress to the vacuum pipelines and/or process equipment.

2 Technical data

Table 2 - Technical data

Pump model	Pump mass (kg)	Maximum load per isolator (kg)	Reduction in height with pump fitted (mm)	Figure number reference	Item Number
Speedivac 2	12.5	5.4	1	1	A248-01-403
E2M1	10.0	2.5	1	2	A248-01-407
E2M1.5	10.0	2.5	1	2	A248-01-407
E2M2	18.2	13.0	-	3	A248-01-404
E1M5	16.8	13.0	-	3	A248-01-404
E2M5	19.6	13.0	-	3	A248-01-404
E1M8	20.0	13.0	-	3	A248-01-404
E2M8	22.8	13.0	-	3	A248-01-404
E2M12	26.0	13.0	-	3	A248-01-404
E1M18	32.0	13.0	-	3	A248-01-404
E2M18	36.0	13.0	1	3	A248-01-404
E2M28	40.0	34.0	1	3	A248-01-412
E1M40	70.5	34.0	1.5	4	A248-01-405
E2M40	72.0	34.0	1.5	4	A248-01-405
E1M80	95.0	34.0	2.5	4	A248-01-405
E2M80	105.0	34.0	2.5	4	A248-01-405
E1M175	194.0	100.00	3.0	5	A248-01-406
E2M175	200.0	100.00	3.0	5	A248-01-406
E1M275	220.0	100.00	3.5	5	A248-01-406
E2M275	225.0	100.00	3.5	5	A248-01-406
DP80	202.0	70.00	3.0	4	A248-01-416
DP180	230.0	100.00	3.5	5	A248-01-414

3 Transit

Vibration Isolators for the smaller pumps have rubber-covered bases to prevent sliding, scratching and vibration when the pump is bench mounted.

During transit the isolators can be clamped to the system frame or other suitable surface as shown in [Figure 1](#). Replace the short bolts supplied with longer bolts to pass through the pump base, the Vibration Isolators and the system frame. Fit washers and nuts and tighten the nuts sufficiently to prevent movement of the pump during transit. After transit, remove the nuts and washers, leaving the clamping bolts in position.

The vibration isolators for the larger pumps are fully captive and are suitable for use in transit, provided the pump is kept upright.

Figure 1 - Using Vibration Isolators during transit

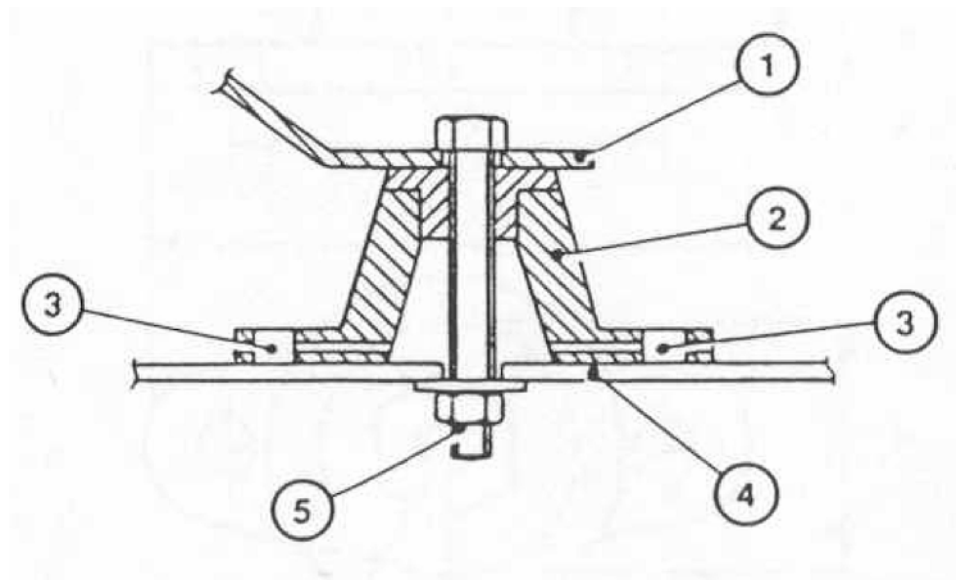

1. Pump base
2. Vibration Isolator
3. Fixing hole
4. System frame
5. Clamping bolt, nut and washer (not supplied)

4 Dimensions

Figure 2 - Dimensions of Vibration isolator for Speedivac 2 pumps

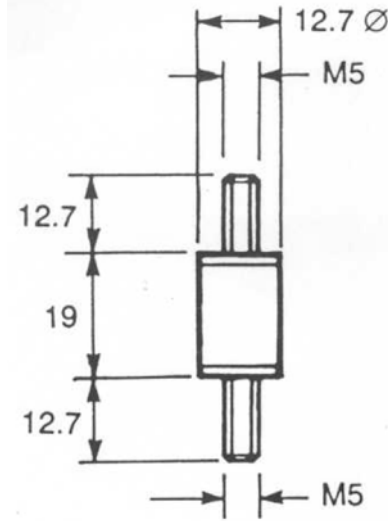

Figure 3 - Dimensions of vibration Isolators for E2M1.5 pumps

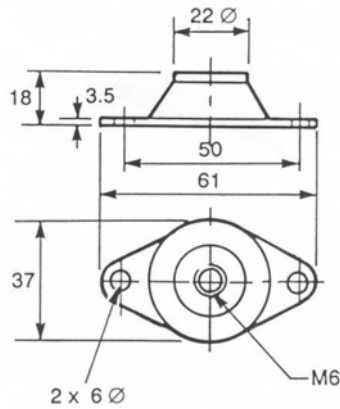

Figure 4 - Dimensions of Vibration Isolator for E2M2, E1M5, E2M5, E1M8, E2M8, E2M12, E1M18, E2M18 and E2M28 pumps

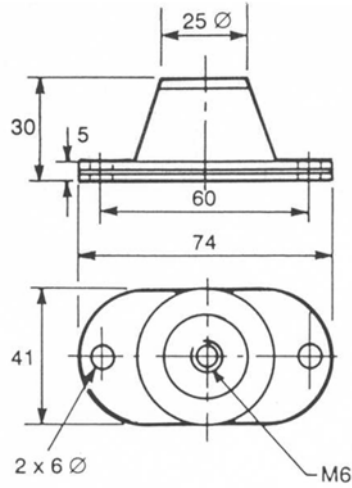

Figure 5 - Dimensions of Vibration Isolator for E1M40, E2M40, E1M80, E2M80 and DP80 pumps

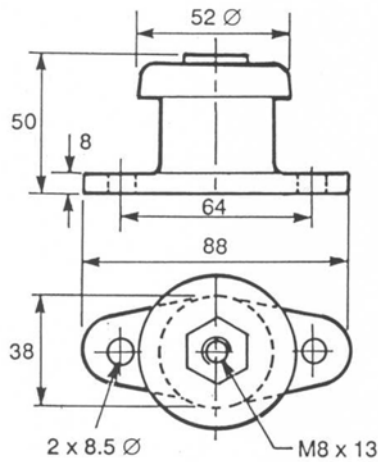
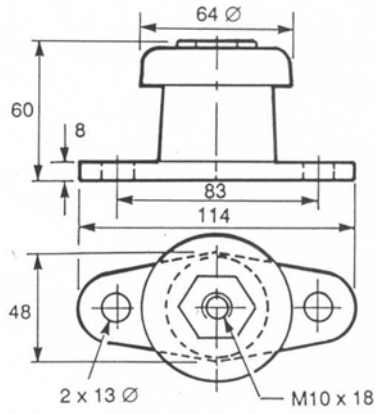

Figure 6 - Dimensions of Vibration Isolator for E1M175, E1M275, E2M275 and DP180 pumps



Return the equipment or components for service

Before you send your equipment to us for service or for any other reason, you must send us a completed Declaration of Contamination of Vacuum Equipment and Components - Form HS2. The HS2 form tells us if any substances found in the equipment are hazardous, which is important for the safety of our employees and all other people involved in the service of your equipment. The hazard information also lets us select the correct procedures to service your equipment.

We provide instructions for completing the form in the Declaration of Contamination of Vacuum equipment and Components - Procedure HS1.

If you are returning a vacuum pump, note the following:

- If a pump is configured to suit the application, make a record of the configuration before returning the pump. All replacement pumps will be supplied with default factory settings.
- Do not return a pump with accessories fitted. Remove all accessories and retain them for future use.
- The instruction in the returns procedure to drain all fluids does not apply to the lubricant in pump oil reservoirs.

Download the latest documents from www.edwardsvacuum.com/HSForms/, follow the procedure in HS1, fill in the electronic HS2 form, print it, sign it, and return the signed copy to Edwards.

Note: *If we do not receive a completed HS2 form, we will not accept the return of the equipment.*

