



[edwardsvacuum.com](http://edwardsvacuum.com)

# Dry Vacuum Pumps nXLi

INSTRUCTION MANUAL

## Copyright notice

©Edwards Limited 2020. All rights reserved.

## Trademark credit

Edwards and the Edwards logo are trademarks of Edwards Limited, Innovation Drive, Burgess Hill, West Sussex RH15 9TW.

## Disclaimer

The content of this manual may change from time to time without notice. We accept no liability for any errors that may appear in this manual nor do we make any expressed or implied warranties regarding the content. As far as practical we have ensured that the products have been designed and constructed to be safe and without risks when properly installed and used in accordance with their operating instructions.

We accept no liability for loss of profit, loss of market or any other indirect or consequential loss whatsoever.

Product warranty and limit of liability are dealt with in our standard terms and conditions of sale or negotiated contract under which this document is supplied.

You must use this product as described in this manual. Read the manual before you install, operate, or maintain the product.

## CE Declaration of Conformity

Edwards Ltd  
Innovation Drive  
Burgess Hill  
West Sussex  
RH15 9TW  
UK

The following product

nXL110i 200 – 240 V 1 PH 50/60 HZ NW40/NW25	A77012320
nXL110i 200 – 240 V 1 PH 50/60 HZ NW50/NW25	A77012420
nXL200i 200 – 240 V 1 PH 50/60 HZ NW40/NW25	A77022320
nXL200i 200 – 240 V 1 PH 50/60 HZ NW50/NW25	A77022420

Is in conformity with the relevant requirements of European CE legislation:

2006/42/EC	Machinery directive
2014/35/EU	Low voltage directive (LVD) as applicable to electrical sub-assemblies
2014/30/EU	Electromagnetic compatibility (EMC) directive
2011/65/EU	Restriction of certain hazardous substances (RoHS) directive as amended by Delegated Directive (EU) 2015/863

Based on the relevant requirements of harmonised standards:

EN 1012-2:1996 +A1:2009	Compressors and vacuum pumps. Safety requirements. Vacuum pumps
EN 61010-1:2010	Safety requirements for electrical equipment for measurement, control and laboratory use. General requirements
EN 61326-1:2013	Electrical equipment for measurement, control and laboratory use. EMC requirements. General requirements Class A Emissions, Industrial Immunity

Documentation Officer: Jelena Havelkova, Spielberk Office Centre, Holandska 10, Brno, 63900 Czech Republic,  
☎: +42(0) 734 418 896, ✉: documentation@edwardsvacuum.com

This declaration, based on the requirements of the listed Directives and EN ISO/IEC 17050-1, covers all product serial numbers from this date on: 13<sup>th</sup> February 2020.



Ian Keech – VP Engineering  
Scientific Vacuum Division  
Burgess Hill



BK Kim – General Manager  
Cheonan, Korea

# Additional Legislation and Compliance Information

## EU EMC Directive: Class A Industrial equipment

Caution: This equipment is not intended for use in residential environments and may not provide adequate protection to radio reception in such environments.

## EU RoHS Directive: Material Exemption Information

This product is compliant with the following Annex III Exemptions:

- 6(b) **Lead** as an alloying element in aluminium containing up to 0.4% by weight
- 6(c) Copper alloy containing up to 4% **lead** by weight
- 7(a) **Lead** in high melting temperature type solder (i.e. lead based alloys containing 85% by weight or more lead)
- 7(c) I Electrical and electronic components containing **lead** in a glass or ceramic other than dielectric ceramic in capacitors, e.g. piezoelectronic devices, or in a glass or ceramic matrix compound
- 7(c) II **Lead** in dielectric ceramic in capacitors for a rated voltage of 125 V AC or 250 V DC or higher
- 8(b) **Cadmium** and its compounds in electrical contacts
- 15 **Lead** in solders to complete a viable electrical connection between semiconductor die and carrier within integrated circuit flip chip packages
- 34 **Lead** in cermet-based trimmer potentiometer elements

## EU REACH Regulation Compliance

This product is a complex article which is not designed for intentional substance release. To the best of our knowledge the materials used comply with the requirements of REACH. The product manual provides information and instruction to ensure the safe storage, use, maintenance and disposal of the product including any substance based requirements.

## Article 33.1 Declaration

This product does contain Candidate List Substances of Very High Concern above 0.1%ww by article as clarified under the 2015 European Court of Justice ruling in case C-106/14.

- Cadmium (Cd) added to the Candidate List June 2013

As indicated by the applied RoHS exemption above, this substance is present in electronic componentry.

- Lead (Pb) added to the Candidate List June 2018

As indicated by the applied RoHS exemption(s) above this substance is present in certain aluminium/brass/steel/electrical or electronic components.

### ADDITIONAL INFORMATION

The products listed are also in scope for and comply with the requirements of the following:

Product is certified to CSA-C22.2 No.61010-1-12 Safety requirements for electrical equipment for measurement, control and laboratory use – Part 1: General requirements

Product conforms to UL61010-1 3<sup>rd</sup> Edition Safety requirements for electrical equipment for measurement, control and laboratory use – Part 1: General requirements

材料成分声明

China Material Content Declaration

部件名称 Part name 	有害物质 Hazardous Substances					
	铅 Lead (Pb)	汞 Mercury (Hg)	镉 Cadmium (Cd)	六价铬 Hexavalent Chromium (Cr VI)	多溴联苯 Polybrominated biphenyls (PBB)	多溴二苯醚 Polybrominated diphenyl ethers (PBDE)
机壳 Enclosure	X	O	O	O	O	O
电机 (泵和机械增压泵) Motors (pump and mechanical booster)	X	O	O	O	O	O
泵和增压泵 Pump and booster	X	O	O	O	O	O
电子元件和控件 Electronics and Controls	X	O	X	O	O	O
冷却系统 Cooling system	X	O	O	O	O	O
吹扫系统 Purge system	X	O	O	O	O	O
机台接口 Tool Interface	X	O	O	O	O	O

O: 表示该有害物质在该部件的所有均质材料中的含量低于 GB/T 26572 标准规定的限量要求。  
O: Indicates that the hazardous substance contained in all of the homogeneous materials for this part is below the limit requirement in GB/T 26572.

X: 表示该有害物质在该部件的至少一种均质材料中的含量超出 GB/T26572 标准规定的限量要求。  
X: Indicates that the hazardous substance contained in at least one of the homogeneous materials used for this part is above the limit requirement of GB/T26572.

This page has been intentionally left blank.

# Contents

<b>1. Safety and compliance.</b>	<b>6</b>
1.1 Definition of Warnings and Cautions.	6
1.2 Safety symbols.	6
<b>2. General description.</b>	<b>7</b>
2.1 Overview.	7
2.2 Pump controller.	8
2.3 Interface control panel.	9
2.4 Logic interface.	9
2.5 Auto-run.	9
2.6 Auxiliary connector socket.	9
2.7 Pump controller configuration.	10
<b>3. Technical data.</b>	<b>12</b>
3.1 Operating and storage conditions.	12
3.2 Performance.	13
3.3 Materials exposed to gases.	14
3.4 Purge gas specification.	15
3.5 Electrical data.	15
<b>4. Installation.</b>	<b>16</b>
4.1 Installation safety.	16
4.2 Unpack and inspect.	17
4.3 Mechanical installation.	18
4.4 Leak test the system.	20
4.5 Electrical installation.	20
4.5.1 Connect the electrical supply.	21
4.6 Connect the system.	21
4.6.1 Purge gas connection.	21
4.6.2 Connection for remote control and monitoring.	21
4.6.3 Connect the logic interface to the control equipment.	21
4.7 Additional safety equipment.	21
<b>5. Commission the pump.</b>	<b>22</b>
<b>6. Operation.</b>	<b>23</b>
6.1 Operation safety.	23
6.2 Operational modes.	24
6.2.1 Manual control mode.	24
6.2.2 Parallel and serial control mode.	24

6.2.3 Auto-run. . . . .	25
6.2.4 Digital operator control mode. . . . .	25
6.3 Start the pump. . . . .	26
6.3.1 Start the pump with the digital operator. . . . .	26
6.3.2 Transient overload protection. . . . .	27
6.3.3 Status indicators. . . . .	27
6.4 Shut down the pump. . . . .	27
6.5 Restart the pump. . . . .	28
<b>7. Maintenance and service. . . . .</b>	<b>29</b>
7.1 General maintenance. . . . .	29
7.2 Service. . . . .	29
7.2.1 Return the equipment or components for service . . . . .	29
<b>8. Fault finding. . . . .</b>	<b>31</b>
8.1 The pump has failed to start or has stopped. . . . .	31
8.2 The pump has failed to achieve the required performance. . . . .	31
8.3 The pump is noisy. . . . .	31
8.4 The pumping speed is poor or pump down time is too long. . . . .	31
8.5 Alarm indicator. . . . .	32
<b>9. Storage. . . . .</b>	<b>33</b>
<b>10. Disposal. . . . .</b>	<b>34</b>
<b>11. Accessories. . . . .</b>	<b>35</b>
11.1 Digital operator. . . . .	35
11.2 Electrical cables. . . . .	35



# List of Figures

Figure 1: nXLi. ....	8
Figure 2: Interface control panel. ....	9
Figure 3: Valve connector. ....	10
Figure 4: nXL110i Dimensions. ....	12
Figure 5: nXL200i Dimensions. ....	13
Figure 6: nXL110i Performance graph. ....	14
Figure 7: nXL200i Performance graph. ....	14
Figure 8: Logic interface connection. ....	25

# 1. Safety and compliance

## 1.1 Definition of Warnings and Cautions

Important safety information is highlighted as WARNING and CAUTION instructions. The safety instructions must be obeyed.

The use of WARNINGS and CAUTIONS is as follows:



### **WARNING:**

Warnings are given where failure to observe the instruction could result in minor injury or death to people. The actual symbol shown varies according to the hazard.









### **CAUTION:**

Cautions are given where failure to observe the instruction could result in minor injury or damage to the equipment, associated equipment or process.

## 1.2 Safety symbols

The safety symbols on the products shows the areas where care and attention is necessary.

The safety symbols that follow are used on the product or in the product documentation.

	Warning/Caution An appropriate safety instruction must be followed or caution to a potential hazard exists.
	Warning - Heavy object Indicates the potential hazard arising from a heavy object.
	Warning - Dangerous voltage Indicates hazards arising from dangerous voltages.
	Warning - Hot surfaces Indicates that the marked item may be hot and should not be touched without taking precautions.
	Warning - Protective earth (ground) Indicates that the equipment must be grounded.
	Warning - Use protective equipment Indicates that appropriate protective equipment must be used.

## 2. General description

### 2.1 Overview



#### **WARNING: INCORRECT USE OF EQUIPMENT**

**Risk of injury or damage to equipment. Incorrect use of the equipment can cause injury. The user is responsible for the safe operation, installation and monitoring of the system.**

The pump is connected by a cord. The pump is designed for use on clean duty applications. The cord ratings are:

- Voltage - 200 - 240 V
- Frequency - 50 or 60 Hz
- Current - 8.5 A

The pump is not designed for use with flammable, corrosive, toxic or other hazardous gases. Gas or oxygen can mix in the pump system.

The compact dry-pumping system operates in steady-state gas load conditions with an inlet pressure from 1 - 15 mbar. If the inlet pressure is more than 15 mbar for an extended period, the pump controller reduces the motor speed. The motor speed is increased when the pressure is reduced, or when the transient overload protection has recovered. Refer to [Table: Performance data](#) on page 13 for information on maximum inlet pressure.

Refer to [Figure: nXLi components](#) on page 8. The system is supplied with a NW40 or NW50 inlet port (item 3) and a NW25 exhaust port (item 2).

The pump mechanism is operated by a three-phase electric motor. The pump controller controls the motor.

The system is air cooled by a fan. The fan is installed between the pump controller and the pump cartridge. The fan continues to operate for 5 minutes after the pump is set to off. The pump has a thermal protection device that will stop the motor if a thermal overload, for example in high ambient temperature occurs. You must restart the pump after it has cooled down.

The system has a purge gas connection, if it is necessary to purge the system.

The pump is designed to remove the residual gases used in high vacuum systems. The gases are:

- Air
- Carbon monoxide
- Neon
- Ethane
- Nitrogen
- Krypton
- Argon
- Helium

- Butane

You can use the pump to pump oxygen and water vapour. The oxygen concentration must be less than 20% by volume. The water vapour must not condense in the pump.

To use the pump to remove a gas that is not listed, speak to the supplier for advice. If you do not get advice before you remove an unlisted gas, your warranty could be invalid. Do not use the pump for aggressive or corrosive gases.

Figure 1 nXLi

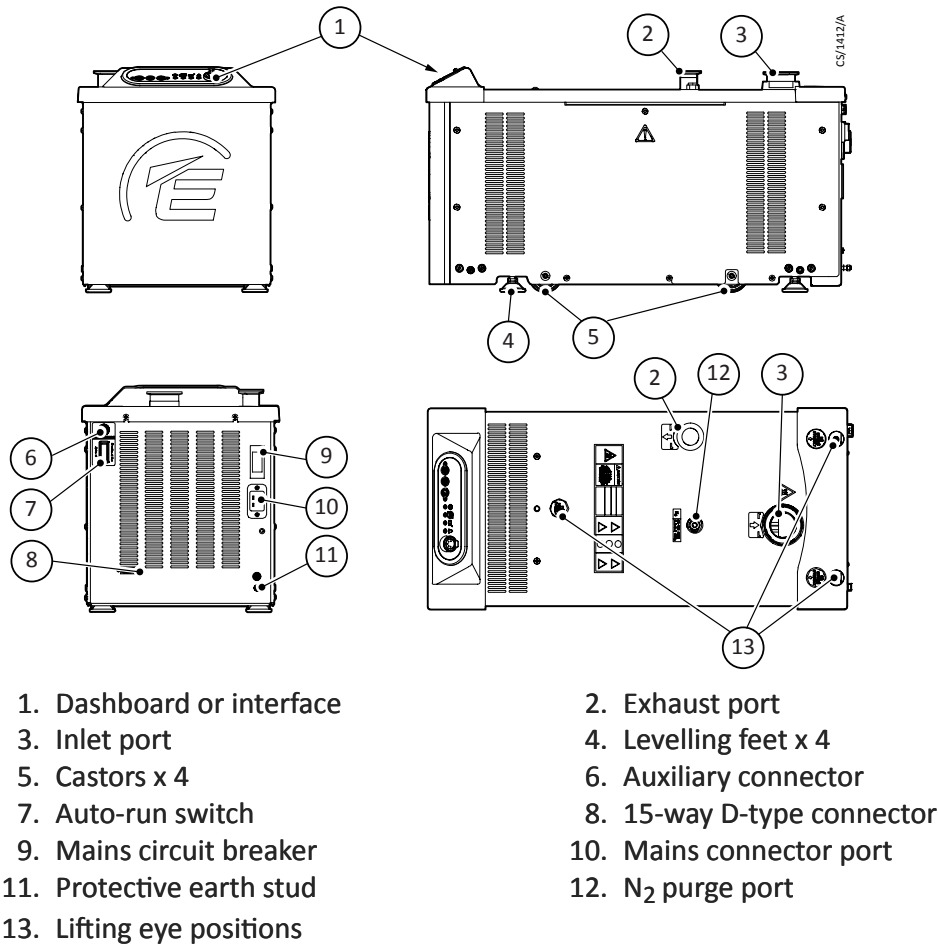

- 1. Dashboard or interface
- 3. Inlet port
- 5. Castors x 4
- 7. Auto-run switch
- 9. Mains circuit breaker
- 11. Protective earth stud
- 13. Lifting eye positions

- 2. Exhaust port
- 4. Levelling feet x 4
- 6. Auxiliary connector
- 8. 15-way D-type connector
- 10. Mains connector port
- 12. N<sub>2</sub> purge port

## 2.2 Pump controller



### CAUTION: ELECTRICAL SUPPLY

**Risk of damage to equipment. Do not disconnect the pump from the electrical supply until it has fully stopped.**

The pump controller contains the drive electronics to control the pump operation.

The pump controller controls the supply of electric current to the motor for the operating conditions. This allows the pump to be connected to a single phase mains supply.

The interface control panel is installed on the pump controller. The pump can be operated:

- manually, with the buttons on the user interface control panel. Refer to [Figure: Interface control panel](#) on page 9.
- remotely, with the serial communications or the digital and analogue process control (parallel). The control is connected to the pump through the 15-way D-type interface connector. Refer to [Figure: nXLi components](#) on page 8 and [Connection for remote control and monitoring](#) on page 21.
- through a digital operator available as an accessory. The digital operator is connected to the pump through a digital-operator connector-socket on the interface control panel. Refer to [Figure: Interface control panel](#) on page 9, item 10.

## 2.3 Interface control panel

Figure 2 Interface control panel

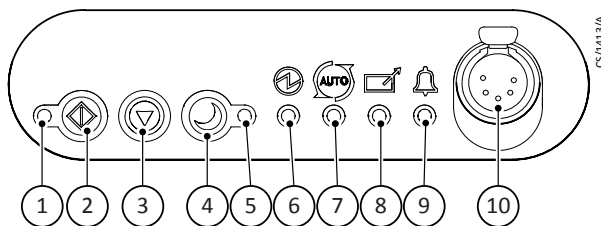

- |                                  |  |
|----------------------------------|--|
| 1. Run indicator LED             | 2. Start button                        |
| 3. Stop button                   | 4. Standby button                      |
| 5. Standby-mode indicator LED    | 6. Power indicator LED                 |
| 7. Auto-run status indicator LED | 8. Remote indicator LED                |
| 9. Alarm indicator LED           | 10. Digital-operator connection-socket |

## 2.4 Logic interface

The logic interface is designed to support the serial control and the parallel control to monitor and control through one connector.

The pump controller can be operated through the 15-way D-type logic interface connector (refer to [Figure: nXLi components](#) on page 8, item 8). The signals on the logic interface are:

- control inputs: switch type and analogue signals that control the pump.
- status outputs: to identify the status of the system.

## 2.5 Auto-run

The pump can be set to auto-run. Use the auto-run switch at the rear of the pump system to set auto-run to on. Refer to [Figure: nXLi components](#) on page 8, item 7.

Refer to [Operational modes](#) on page 24 for more information.

## 2.6 Auxiliary connector socket

An auxiliary control connection on the rear panel controls an optional inlet valve. This inlet valve can be operated in parallel with the normal pump output signal. Refer to [Figure: nXLi components](#) on page 8, item 6. The valve is usually closed and:

- will open when the normal signal is active (pump at speed)

- will close when you select stop, or if there is a fault condition.

The reaction time will be in line with the valve selection. The output signal is 24 V d.c. Refer to [Figure: Valve connector](#) on page 10 for the polarity of the connector pins when the connector is energized.

The auxiliary connector is regulated to 24 V d.c. to control the accessories. Refer to [Table: Auxiliary load currents](#) on page 10, the output will shut down to protect the pump controller.

Refer to [Table: Recommended mating plugs](#) on page 10 for the recommended mating plugs.

**Figure 3** Valve connector

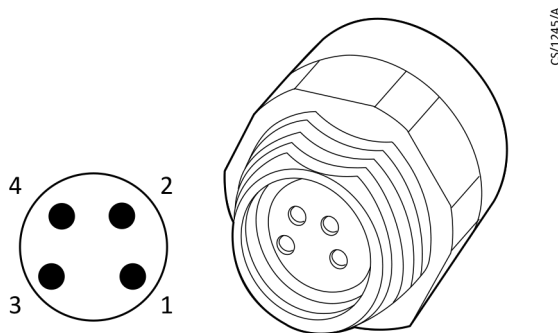

Pin number	Signal	Polarity
1	0 V return	Negative
2	Not connected	-
3	Not connected	-
4	Switched +24 V	Positive

**Table 1** Auxiliary load currents

Description	Data
Connector plug	Phoenix part number SACC-DSI-M 8FS-4CON-M12/0.5
Voltage output	24 V d.c. -25%, +10% (18 V d.c. to 26.4 V d.c.)
Current output	500 mA

**Table 2** Recommended mating plugs

Mating connector plug	Phoenix part number
Screw connection, straight	SACC-M 8MS-4CON-M-SW
Solder connection, straight	SACC-M 8MS-4CON-M
Screw connection, right angle	SACC-M 8MR-4CON-M-SW
Solder connection, right angle	SACC-M 8MR-4CON-M

## 2.7 Pump controller configuration

You can use a separate system to configure the pump controller before you connect the pump to the application. All the configuration settings stored in the pump controller are saved when the power to the pump is disconnected.

## A77010880\_B - General description

You can configure the pump functionality for the application. This allows the pump to operate through a simple parallel interface system.

### 3. Technical data

#### 3.1 Operating and storage conditions

**Table 3** Operating and storage conditions

Range	Data
Ambient operating temperature range	5 °C to 40 °C
Ambient operating humidity range	10% to 90% RH (non-condensing)
Maximum operating altitude	2000 m
Ambient storage temperature range	-30 °C to 70 °C
Pollution degree	2
Equipment type	Indoor use
Enclosure protection	IP20

**Note:**

The nXLi pump-system is designed to meet the electrical safety creepage and clearance requirements for 3000 m altitude. For maximum thermal performance, de-rating is required between 2000 m and 3000 m. Reduce the maximum operating ambient temperature from 40 °C to 35 °C between 2000 m and 3000 m linearly. This de-rating meets the requirements of IEC 282-1.2.

**Table 4** Mechanical data

Parameter	nXL110i	nXL200i
Overall dimensions (L x W x H)	654 x 308 x 344 mm	704 x 308 x 343 mm
Maximum tilt angle	25°	
Nominal rotational speed	9000 rpm	
Mass	78 kg	84 kg
Inlet connection	NW40 or NW50	
Outlet connection	NW25	

**Figure 4** nXL110i Dimensions

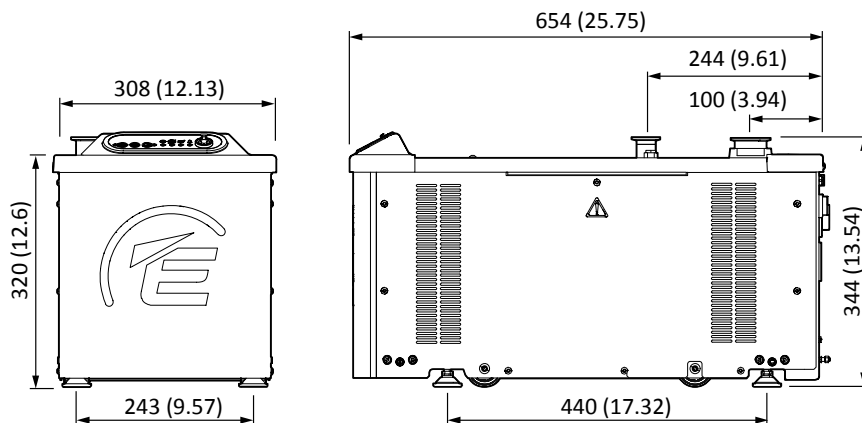
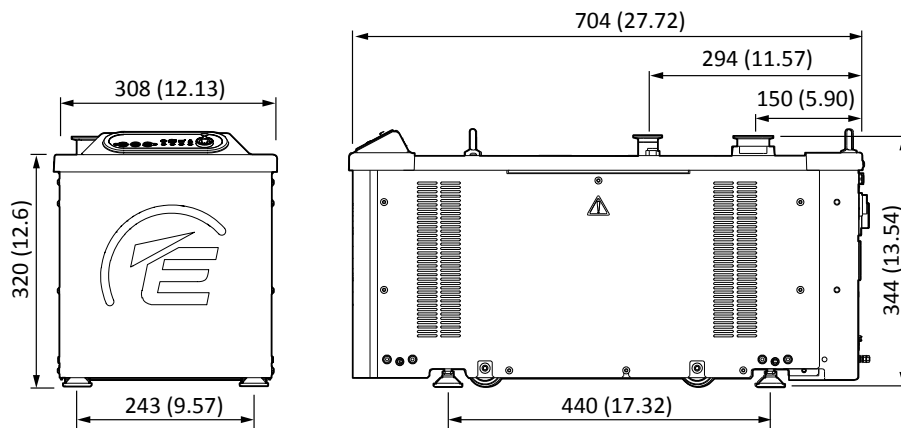



Figure 5 nXL200i Dimensions



## 3.2 Performance

Table 5 Performance data

Parameter	Units	nXL110i	nXRL200i
Maximum pump speed*	m <sup>3</sup> /hr	110	200
Maximum continuous inlet pressure at 40 °C ambient	mbar	8	
Maximum continuous inlet pressure at 30 °C ambient	mbar	15	
Maximum continuous exhaust pressure	bar	0.4	
Maximum inlet flow to pump down a 100 litre chamber from an atmospheric pressure	slm	0	NA
Maximum inlet flow to pump down a 75 litre chamber from an atmospheric pressure	slm	5	0
Maximum inlet flow to pump down a 50 litre chamber from an atmospheric pressure	slm	25	20
Suck-back protection		By exhaust valve	
Leak tightness (static)	mbar l/s <sup>-1</sup>	< 1 x 10 <sup>-5</sup>	

\* Values for the maximum pumping speed are taken at a sea level. At level higher than sea level, the pump performance can be affected and the rotational speed can drop below the nominal value.

**Table 6** Sound data

Declared dual-number noise-emission values in accordance with ISO 4871		
	nXL100i	nXL200i
Measured A-weighted emission sound pressure level, $L_{pA}$ at ultimate vacuum 1 m from the pump in free space dB(A)	56.7	55.4
Uncertainty, $K_{pA}$ dB(A)	2.5	
Values from ISO 3744: 2010		

**Figure 6** nXL110i Performance graph

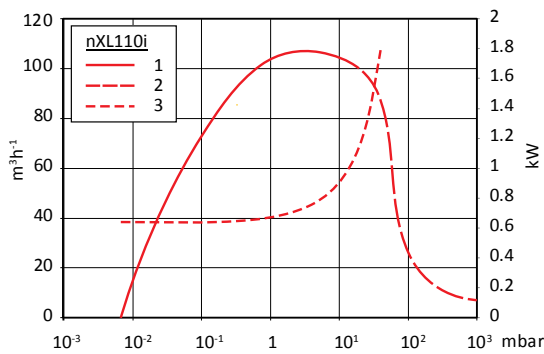

1. nXL110i
2. nXL110i in transient overload protection
3. Supply power (kW)

**Figure 7** nXL200i Performance graph

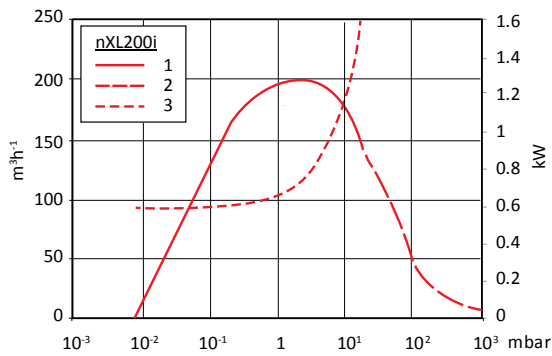

1. nXL200i
2. nXL200i in transient overload protection
3. Supply power (kW)

### 3.3 Materials exposed to gases

The materials and the components exposed to the gases in the pump are:

- SG iron
- Aluminium alloy
- Steel
- Fluoroelastomer (seals)
- PTFE (seals)

### 3.4 Purge gas specification

**Table 7** Purge gas specification

Specification	Reference data
Purge gas	Dry air, nitrogen, argon or other inert gases
Purge gas interface	8 mm tube compression fitting
Maximum allowable purge gas supply pressure	7 bar (gauge), 100 psig, $7 \times 10^5$ Pa
Minimum allowable purge gas supply pressure	3 bar (gauge), 45 psig, $3 \times 10^5$ Pa
Minimum purity	ISO 8573 solids class 1
Typical flow at 3 bar	4 slm

### 3.5 Electrical data

**Table 8** Electrical rating for continuous operation

Supply voltage (V a.c. rms)	Phase	Frequency (Hz)	Input current (A rms)
200 - 240 +/-10%	Single	50 - 60	8.5

 **Note:**

*In a transient overload condition the maximum overload current drawn by the pump is 10 amps. Refer to [Transient overload protection](#) on page 27 for more information.*

## 4. Installation

### 4.1 Installation safety



#### CAUTION: SAFETY INSTRUCTIONS

**Risk of injury or damage to equipment. Follow the safety instructions and take note of all appropriate precautions.**

Possible hazards on the dry pumping system include electricity, process chemicals, Fomblin® (PFPE) oil and nitrogen.

- Refer to safety manual P40040100 for safety information for the specification, design, operation and maintenance of vacuum pumps and vacuum systems. Contact us for the safety manual.
- Contact us or the local service centre for installation advice or assistance.
- Do not remove the temporary covers from the system inlet and exhaust until the system is ready to connect.
- Do not operate the system until the inlet and exhaust are connected to the vacuum and the exhaust extraction system.
- If the pump is to replace an existing pump system, we recommend that you vent and purge the system. Vent and purge the system with nitrogen for minimum 15 minutes before you start the installation. Refer to [Purge gas specification](#) on page 15.
- Isolate the other components in the process system from the electrical supply to prevent accidental operation.
- Electrical and nitrogen supplies are possible hazards. Lockout and tagout the supplies before you do maintenance.
- Obey all national and local rules and safety regulations when you install the system.
- Tighten the cables, hoses and pipework during installation to prevent a trip hazard.
- Make sure that the installation area is clean and free from debris and contamination before you install the pump.
- Make sure that all facilities given in this manual are available for the system to perform correctly.
- Make sure that the exhaust is connected to the correct treatment plant to prevent the discharge of the exhaust to the atmosphere.
- Make sure that the exhaust pipeline will not be blocked during operation. If an exhaust isolation valve is used, make sure that the pump cannot be operated when the valve is closed.

## 4.2 Unpack and inspect



### WARNING: DAMAGED PUMP

Risk of injury to people or damage to equipment. Do not use the pump if it is damaged. Failure to do so can result in injury to people and/or damage to equipment.



### CAUTION: PUMP LIFE

Risk of damage to equipment. Unpack the pump carefully and avoid excessive shock to the pump. Excessive shock will damage the bearings and reduce the life of the pump.

Refer to [Table: Mechanical data](#) on page 12 for the mass of the pump.

The pump is attached to a wooden pallet with metal brackets in a cardboard package. The metal brackets must be removed and kept.

1. Open the cardboard box from the top.
2. Remove the packing material. Keep all the packing materials for use in inspection and if the pump is returned for service.
3. Examine the pump for damage. If the pump is damaged, tell your supplier and the carrier immediately. Give the supplier and the carrier the information that follows:
  - serial number of the pump
  - order number
  - supplier's invoice number
4. Do not use the pump if the pump is damaged.
5. Check that the package has the items listed in [Table: Checklist of items](#) on page 17. If the items are missing, notify the supplier in writing within three days.
6. If the pump is not to be used immediately, store the pump in the conditions given in [Storage](#) on page 33.
7. Do not remove the seals until the pump is ready to be installed on the vacuum system. The pump is supplied with sealed inlets and outlet to prevent the entry of dust and vapour.

**Table 9** Item checklist

Quantity	Description	Check
1	nXLi vacuum pump	<input type="checkbox"/>
3	Lifting eye	<input type="checkbox"/>
1	Instruction manual CD (P45000000)	<input type="checkbox"/>

## 4.3 Mechanical installation



### **WARNING: HEAVY OBJECT**

Risk of physical injury. Use suitable equipment to lift the pump.



### **WARNING: TRIPPING HAZARD**

Risk of injury or damage to equipment. Make sure that cables or pipe work attached to the pump are installed carefully to prevent a slip or trip hazard and the damage to the cable.



### **WARNING: LIFTING EYE INTEGRITY**

Risk of injury or damage to equipment. Make sure that the maximum angle between the paired slings used to lift the system is 45 degrees. Increased angle could decrease the lifting eye integrity.



### **WARNING: INSTALLATION SAFETY**

Risk of injury or damage to equipment. Install the pump in the vacuum system before you connect the pump to the power supply. This will make sure that the pump is not operated and injure people during installation.



### **WARNING: TOPPLE HAZARD**

Risk of damage to equipment. Do not exceed the topple angle when you move the pump or the pump can fall over and injure people.



### **WARNING: HEAVY OBJECT**

Push-pull hazard with strain injury. Push or pull the pump system only for short distance and over flat surfaces. Lift the system if the floor is uneven or has obstacles.



### **CAUTION: INSTALLATION SAFETY**

Risk of damage to the environment. Obey all local legislation when the pump is installed or removed to reduce the impact of the pump on the environment.



### **CAUTION: CONDENSATE DRAINAGE**

Risk of damage to equipment. Use a catchpot to prevent the drainage of condensate back into the system. Condensate that drains back into the system could damage the pump.

 **Note:**

*The shipping brackets that are used to attach the pump to the shipping pallet can be used for seismic restraint. The shipping brackets are designed to withstand a level 4 earthquake at a ground floor installation.*

Obey the instructions that follow when you install the pump:

- Make sure that there is no blockage to access the pump electrical supply cable or the other controls.
- Make sure that there is a minimum air gap of 40 mm on all sides of the pump to allow effective air circulation.
- Make sure that the system is on a firm and levelled surface that can support the mass of the pump.
- Make sure that the system is installed away from combustible materials.
- You must do a risk assessment of the location and make sure that you can move the pump safely and as per the local and national manual handling guidelines.

To attach the system to the floor:

1. Put the M10 (class 12.9) bolts (not supplied) in the slotted holes of the shipping brackets to attach the the system to the floor.
2. Tighten the M10 (class 12.9) bolts.
3. If the vibration transmission to the floor is a problem, install the applicable vibration isolators (not supplied) between the brackets and the tie bolt or the stud.
4. Level the pump to a maximum of 5 degrees (measured at the pump inlet).

To move the pump:

1. Attach the correct lifting equipment to all 3 lifting eyebolts. Refer to [Figure: nXLi components](#) on page 8, item 13.
2. Move the pump carefully to the installation area. Refer to [Table: Mechanical data](#) on page 12 for weight of the pump.
3. Adjust the levelling feet ([Figure: nXLi components](#) on page 8, item 4) to make sure that the dry pumping system is levelled and not supported by the castors. The recommended jacking height is 5 mm.
4. Remove the plastic caps from the inlet and exhaust before you connect the pump to the vacuum system. Use appropriate NW vacuum fittings for the connection to the system.

Obey the instructions that follows when you connect the pump to the vacuum system:

- Connect the pump to an exhaust line to minimize the noise and the exhaust emissions.
- Make sure that the pipeline connected to the pump inlet is as short as possible. Make sure that the pipeline has a minimum internal diameter to get maximum pump speeds.
- Put support under the vacuum pipeline to prevent the load on the coupling joints.
- Make sure that the pump exhaust line is not blocked as a pressure of 3 bar(g) can be generated in the exhaust pipework. Connect the pump with appropriate pipework and fittings.
- If necessary, install flexible bellows in the system pipelines to reduce the transmission of the vibration and to prevent the load on the coupling joints. The

pressure rating of the bellows must be higher than the highest pressure generated in the system. We recommend that you use the manufacturer's bellows.

- Install an inlet isolation valve in the pipeline between the vacuum system and the pump. The inlet isolation valve isolates the vacuum system from the pump when the system is set to off. This prevent the flow of the process gases and particles back into the vacuum system.
- Make sure that the sealing surfaces are clean and are not scratched.
- We recommend that you use an exhaust extraction system appropriate for use with all pumped process gases. Make sure that the exhaust extraction system is not blocked or obstructed when the pump is in operation.

## 4.4 Leak test the system



### CAUTION: SYSTEM LEAK TEST

**Risk of injury or damage to equipment. Do the leak test of the system after installation. Seal all the leaks found to prevent leakage of dangerous substances out of the system and leakage of air into the system.**

We will accept no liability or warranty claims for damages caused from flammable mixtures because of air leaks.

1. Do the leak test of the vacuum system after installation.
2. Seal all the leaks found.

## 4.5 Electrical installation



### WARNING: ELECTRICAL CONNECTION

**Risk of electric shock. The electrical installation must be done by a qualified person. Always make the electrical connections to the pump after the pump has been installed on the vacuum system.**



### WARNING: INSTALLATION SAFETY

**Risk of electric shock or damage to equipment. The pump must be electrically installed in accordance with regional and local codes, and must obey the local and national safety requirements.**



### WARNING: HAZARDOUS VOLTAGE

**Risk of electric shock or damage to equipment. The logic interface is 30 V maximum rated PELV and must only be connected to PELV interfaces. Failure to use an correctly rated supply could result in electric shock.**

The pump is a cord-connected device rated at 8.5 A and must be installed in accordance with local electrical regulations. The pump is to be supplied from a single phase 200 - 240 V branch circuit protected supply rated at 15 A maximum. Refer to [Table: Recommended cord sets](#) on page 35.



## 4.5.1 Connect the electrical supply



### **WARNING: PROTECTIVE EARTH**

Risk of electric shock. Make sure that the pump and electrical cables are protected against earth (ground) faults. It is recommended that a protective earth (ground) conductor (with a cross sectional area of 2.5 mm<sup>2</sup> / 13 AWG be fitted to the protective earth (ground) stud.

Make the electrical connection to the pump mains connector port (*Figure: nXLi components* on page 8, item 10) with an appropriate cord set. Refer to *Table: Recommended cord sets* on page 35.

The pump must be grounded through the earth (ground) conductor of the IEC60320 connector.

## 4.6 Connect the system

### 4.6.1 Purge gas connection



### **WARNING: HAZARDOUS SUBSTANCES**

Risk of explosion. The pump is intended for clean applications only. It is not suitable for use with hazardous production materials.

Make sure that the nitrogen supply and the purge supply are as the values in *Table: Purge gas specification* on page 15 to prevent a blockage.

Refer to *Figure: nXLi components* on page 8, item 12 for the location of the nitrogen purge port.

Gas purge is used for movement of inert light gases, such as helium.

### 4.6.2 Connection for remote control and monitoring

To operate the pump with parallel or serial control, use the 15-way D-type connector. *Figure: nXLi components* on page 8, item 8

Refer to *Figure: Logic interface connection* on page 25 for details of the logic interface pins.

### 4.6.3 Connect the logic interface to the control equipment

The pump can be controlled, with a hardware parallel control interface through commands sent over a serial interface. Refer to *Parallel and serial control mode* on page 24 for more information.

To control the pump through the serial interface, please contact us for information.

## 4.7 Additional safety equipment

If necessary, install appropriate measurement equipment in the nitrogen supply pipeline. This is used if you need to monitor the total flow rate of nitrogen to the pump.

## 5. Commission the pump

To commission the pump:

1. Set the external electrical supply to ON.
2. Set the mains circuit breaker (*Figure: nXLi components* on page 8, item 8) to ON. Make sure that the power indicator LED (*Figure: Interface control panel* on page 9, item 14) illuminates. If the LED does not illuminate, contact us.
3. If necessary, set the nitrogen supply to ON.
4. Make sure that the exhaust extraction system is not blocked (for example, the valves in the exhaust extraction system are open).
5. Make sure that all openings to atmospheric pressure in the foreline vacuum system are closed.
6. Refer to *Figure: Interface control panel* on page 9. Push and hold the start button (item 1) until the run indicator LED (item 13) begins to flash.
7. If the dry pumping system starts and continues to operate, continue at Step 7. If an alarm condition is indicated:
  - A. shut down the dry pumping system. Refer to *Shut down the pump* on page 27.
  - B. contact us.
8. After you commission the dry pumping system:
  - A. to continue to operate the system, refer to *Start the pump* on page 26.
  - B. to shut down the system, refer to *Shut down the pump* on page 27.

## 6. Operation

### 6.1 Operation safety



#### **WARNING: DAMAGED PARTS**

Risk of electric shock. Do not operate the pump with any parts of the enclosures removed or damaged as there can be a risk of an electric shock.



#### **WARNING: OPERATIONAL SAFETY**

Risk of injury or death. Do not expose any part of the human body to vacuum as this can result in injury or death of people.



#### **WARNING: PUMP TEMPERATURE**

Risk of injury. Do not touch the pump inlet manifold or exhaust when the pump is in operation as the pump inlet manifold and exhaust can get hot. Allow the pump to cool down after the pump has stopped.



#### **CAUTION: AUTOMATIC START**

Risk of injury or damage to equipment. The system has an auto-run mode which, if configured, is designed to automatically start the pump system once power is applied.



#### **CAUTION: CONDENSATE DEPOSITION**

Risk of damage to equipment. Do not use the pump to pump particulates or condensate. Deposition may occur in the pump. This can degrade the pump performance and reduce the pump life.



#### **CAUTION: MAXIMUM CONTINUOUS OPERATING PRESSURE**

The pump can be controlled, stopped or put in standby mode only through the interface used to start the pump. In auto-run mode, the stop button on the user interface panel will override the starting interface and stop the pump.

 **Note:**

*Do not exceed the maximum continuous operating pressure.*

 **Note:**

*This is an industrial (Class A, Group 1) product as defined by EN55011 and EN61325. To ensure compliance with European Electromagnetic Compatibility (EMC) requirements for EMC emissions, please note that it is not intended for use in domestic buildings or in properties directly connected to an electrical supply network which also supplies*

domestic buildings. "Group 1" is defined as equipment which does not use RF energy as an intrinsic part of operation or process.

## 6.2 Operational modes

The pump can be controlled through:

- Manual control mode – with the buttons on the user interface panel
- Parallel control mode – through the 15-way D-type logic interface connector located at the rear of the pump
- Serial control mode – through the 15-way D-type logic interface connector located at the rear of the pump
- Auto-run

In addition to the control modes, you can control the pump through a digital operator. Refer to [Table: Digital operator](#) on page 35 control mode for more details.

### 6.2.1 Manual control mode

Refer to [Figure: Interface control panel](#) on page 9 for the pump control functions.

#### Start and stop

Use the buttons on the user interface of the control panel to start and stop the pump.

 **Note:**

*The stop command does not isolate the pump from the electrical supply.*

When the pump accelerates to full speed, the run indicator LED will flash (refer to [Figure: Interface control panel](#) on page 9, item 1). When the pump reaches the full speed the run indicator LED will no longer flash and stay illuminated. If an inlet valve is installed, the inlet valve will open when the pump reaches full speed.

#### Standby

In standby mode the pump operates at a reduced speed to improve the service life of the pump. Vacuum performance is reduced when the pump operates at standby speed.

1. Push the standby button to select standby mode. The standby mode indicator LED (refer to [Figure: Interface control panel](#) on page 9, item 5) will illuminate. The pump will run at factory default standby speed (89% of full speed).
2. Push the standby button to return to normal run speed. The standby mode indicator LED will go out.

### 6.2.2 Parallel and serial control mode

You can remotely operate the pump with the 15-way D-type connector installed on the panel at the rear of the pump. Refer to [Figure: nXLi components](#) on page 8, item 8.

The 15-way D-type connector is PELV-double insulated. We recommend that you use the galvanic isolated relay contacts to prevent the ground loops or unwanted EMC issues.

The available controls are:

- Run
- Stop
- Normal
- OK signal
- Standby

Refer to [Figure: Logic interface connection](#) on page 25 for the the control function connections.

The auto-run switch (refer to [Figure: nXLi components](#) on page 8, item 7) must be in the off position for remote operation. Make sure that the pump is not in control by the other interface to prevent the lock-out of the remote interface.

**Figure 8** Logic interface connection

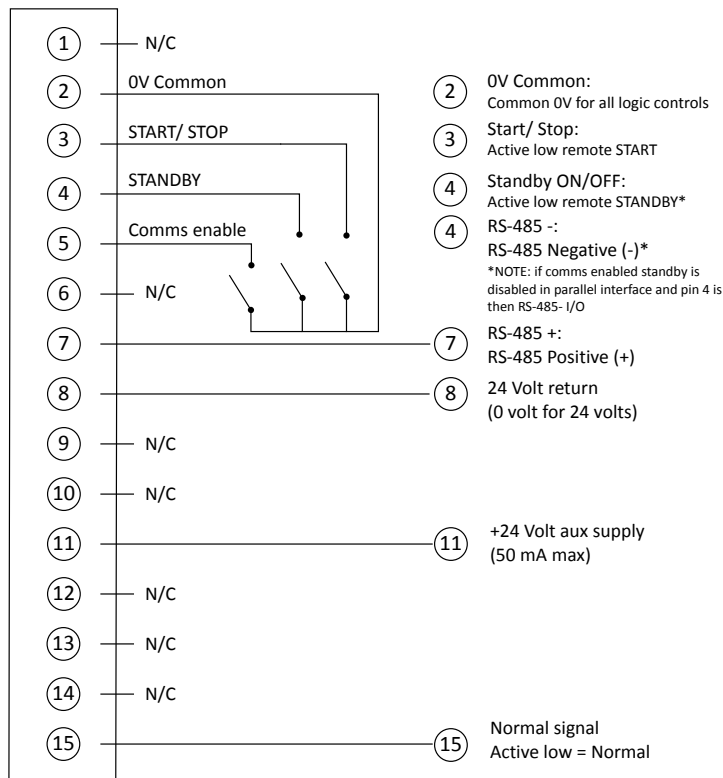

### 6.2.3 Auto-run

When the auto-run switch is in the on position:

- the pump system will start when the power is supplied.
- the pump system will stop when the power is disconnected.

When the auto-run switch is in the off position, you can start or stop the pump system through one of the control modes.

### 6.2.4 Digital operator control mode

You can control the pump through a digital operator. The digital operator is available as an accessory. The digital operator is connected to the pump through the digital operator

connector socket on the user interface panel. Refer to [Figure: Interface control panel](#) on page 9, item 10.

Refer to [Start the pump with the digital operator](#) on page 26 for more instructions.

## 6.3 Start the pump



### **WARNING: EXHAUST PIPELINE BLOCKAGE**

**Risk of damage to equipment. Do not operate the pump if the exhaust pipeline is restricted or blocked. The pump will not operate correctly and can be damaged.**

1. Make sure that the vacuum system isolation valve is closed (if installed).
2. Make sure that the mains supply to the pump is isolated.
3. Connect a electrical connection to the mains connector port of the pump ([Figure: Interface control panel](#) on page 9, item 10) with an IEC60320 connector (C19).
4. Make sure that the exhaust extraction system is not restricted and that the valves in the exhaust extraction system are open.
5. Supply the power.
6. Start the pump with the applicable control source that follows:
  - manual control mode - push the start button, refer to [Figure: Interface control panel](#) on page 9, item 2
  - parallel control mode - use the start, stop control input
  - serial control mode - use the start command
7. Open the vacuum system isolation valve (if installed).

### 6.3.1 Start the pump with the digital operator

1. Use the supplied cable to connect the digital operator to the digital operator connection socket. Refer to [Figure: Interface control panel](#) on page 9, item 10.
2. When the digital operator is connected, the screen shown in [Figure: Screen view of the digital operator](#) on page 26 is displayed.
3. Push the LO/RE button to take control with the digital operator. The LO/RE LED light will illuminate when the digital operator has control.
4. To start the pump, push the RUN button. The pump will start and accelerate up to the reference frequency of 450 Hz. The RUN LED light illuminates when the pump is in operation.
5. To stop the pump, push the STOP button. The RUN LED flashes until the motor decelerates and stops completely.

You can see the parameters shown in [Table: Displayed parameters](#) on page 26 on the display screen when the pump is in operation. To view other parameters, refer to the digital operator user manual or contact us.

**Table 10** Displayed parameters

Code	Description
U1-01	Reference frequency (set to 450 Hz)
U1-02	Actual frequency (Hz)

Code	Description
U1-03	Output current (A)

### 6.3.2 Transient overload protection

The pump has an overload protection function. If the load is more than the capacity of the pump, the pump will stop momentarily and restart automatically to operate. The cycle will repeat for a maximum 10 times. If the pump continues to be in the overload condition:

- the pump will trip
- the alarm indicator LED will show a constant RED
- the pump will stop.

### 6.3.3 Status indicators

Refer to [Figure: Interface control panel](#) on page 9 for details.

## 6.4 Shut down the pump



#### CAUTION: PUMP SUPPLY ISOLATION

**Risk of injury. Do not remove the inlet connections until the pump stops rotating and the power and nitrogen supply has been isolated. The pump can take up to 3 minutes to fully stop.**



#### WARNING: ELECTRICAL SUPPLY

**Risk of damage to equipment. Do not disconnect the pump from the electrical supply until the pump has fully stopped.**

You can shut down the pump with:

- the front panel controls
- the digital operator (if installed)
- the 15-way D-type connector in either parallel or serial control mode.

**Note:**

*Only the item in control can stop the pump. If the pump is in auto-run mode, use the stop button on the user interface control panel to stop the pump.*

To shut down the pump, obey the instructions that follow:

1. Close the vacuum system isolation valves (where installed) to prevent the flow of the liquid back into the vacuum system.
2. Stop the pump system with the applicable control source that follows:
  - manual control mode - push and hold the stop button ([Figure: Interface control panel](#) on page 9, item 3)
  - parallel control interface - use the start, stop control input
  - serial control mode - send a stop command

- digital operator - push the stop button
3. When the pump is set to off, the fan will operate until the pump cools down.
  4. Vent the pump through the inlet.
  5. Isolate the mains supply.

## 6.5 Restart the pump

If the pump is shut down automatically because of high pump power make sure the pump rotates freely. Restart the pump. If the problem occurs again, contact us..

If the pump is shut down automatically because of an alarm condition, correct the alarm condition before you start the pump. To restart the pump, refer to [Operation](#) on page 23.



## 7. Maintenance and service

### 7.1 General maintenance

The system requires no user maintenance. Maintenance must be done by our service centres. The frequency of the maintenance depends on the process. The frequency of the maintenance can be adjusted based on pump use.

We recommend a monthly visual inspection of the dry pump system. Check that the electrical supply cord, hoses and pipelines connected to the pump are in good condition and tightened.

### 7.2 Service

It is recommended that the pump should be serviced every 5 years. The pump should then be returned to an Edwards Service Technology Centre.

Our products are supported by a world-wide network of Service Technology Centres offering a wide range of options including:

- Complete remanufacturing (includes 6 months warranty)
- Exchange pump (includes 12 months warranty)

Both services include decontamination, repair, rebuild and test to factory specification.

A local Service Technology Centre can also provide trained engineers to support the exchange pump option. For more information about service options, contact us or the nearest Service Centre.

#### 7.2.1 Return the equipment or components for service

Before you send your equipment to us for service or for any other reason, you must send us a completed Declaration of Contamination of Vacuum Equipment and Components – Form HS2. The HS2 form tells us if any substances found in the equipment are hazardous, which is important for the safety of our employees and all other people involved in the service of your equipment. The hazard information also lets us select the correct procedures to service your equipment.

We provide instructions for completing the form in the Declaration of Contamination of Vacuum equipment and Components – Procedure HS1.

If you are returning a vacuum pump, note the following:

- If a pump is configured to suit the application, make a record of the configuration before returning the pump. All replacement pumps will be supplied with default factory settings.
- Do not return a pump with accessories fitted. Remove all accessories and retain them for future use.
- The instruction in the returns procedure to drain all fluids does not apply to the lubricant in pump oil reservoirs.

Download the latest documents from [www.edwardsvacuum.com/HSForms/](http://www.edwardsvacuum.com/HSForms/), follow the procedure in HS1, fill in the electronic HS2 form, print it, sign it, and return the signed copy to us.



**NOTICE:**

**If we do not receive a completed HS2 form, your equipment cannot be serviced.**

## 8. Fault finding

A list of fault conditions and their possible causes is given to assist in basic troubleshooting. If you are not able to correct a fault, call your supplier or your nearest manufacturer service centre for advice.

<b>Fault</b>	<b>The pump has failed to start or has stopped</b>
<b>Cause</b>	<b>The electrical supply fuse has blown.</b>
<b>Remedy</b>	Make sure that the external electrical supply is set to on and that the power indicator LED ( <i>Figure: Interface control panel</i> on page 9, item 14) is illuminated. If the LED does not illuminate, contact us.
<b>Cause</b>	<b>The motor controller has not reset after an over temperature event.</b>
<b>Remedy</b>	Disconnect the main power supply and wait for at least one minute and attempt to restart the pump. If the pump still does not start, contact us.
	If the alarm indicator LED ( <i>Figure: Interface control panel</i> on page 9, item 5) flashes, it indicates that the pump has high current load from possibly a high inlet pressure/flow. Adjust the inlet pressure/flow until the pump performance recovers.
<b>Fault</b>	<b>The pump has failed to achieve the required performance</b>
<b>Cause</b>	<b>The pressure measurement technique or gauge head is not suitable or gives an incorrect indication of pressure.</b>
<b>Remedy</b>	Make sure that the vacuum measurement equipment is calibrated and is updated. The correct gauge range must be selected for the application. Contact us for further assistance on gauge selection, if required.
<b>Cause</b>	<b>The vacuum fittings are dirty or damaged.</b>
<b>Remedy</b>	Make sure that the vacuum fittings are clean and scratch free.
<b>Cause</b>	<b>There is a blockage or high pressure in the exhaust line.</b>
<b>Remedy</b>	Make sure that the exhaust valves fitted are not closed when the pump is in operation.
<b>Cause</b>	<b>The motor controller is current limiting the supply.</b>
<b>Remedy</b>	If the alarm indicator LED ( <i>Figure: Interface control panel</i> on page 9, item 5) flashes, the pump has high current load, possibly from a high inlet pressure/flow. Adjust the inlet pressure/flow until the pump performance recovers.
<b>Fault</b>	<b>The pump is noisy</b>
<b>Cause</b>	<b>The pump is contaminated with solid particles.</b>
<b>Remedy</b>	Contact us or the supplier for further information.
<b>Fault</b>	<b>The pumping speed is poor or pump down time is too long</b>
<b>Cause</b>	<b>The pipelines connections are too small in diameter.</b>

Remedy Make sure that the pipework has sufficient conductance (user's responsibility) and the pump performance is not compromised.

**Cause** There is a leak in the system.

Remedy Do the leak test of the pump system in accordance with the requirements specified in [Table: Performance data](#) on page 13.

**Cause** The motor controller is current limiting the supply.

Remedy Adjust the inlet pressure/flow until the pump performance recovers.

**Cause** The pump chamber is too big.

Remedy Make sure that the chamber size is not more than the limits specified in [Table: Mechanical data](#) on page 12.

## 8.1 Alarm indicator

If the red alarm indicator LED ([Figure: Interface control panel](#) on page 9, item 9) is illuminated, contact us for further information.

Before you perform the fault finding, lockout and tagout the electrical and nitrogen supplies.

## 9. Storage



### **WARNING: HAZARDOUS SUBSTANCES**

**Do not drain oil from the pump. Install the blanking plates to seal the vacuum inlet and outlet ports to prevent the possible oil leakage. Make sure that the pump is correctly labelled. If in doubt, contact us.**

1. Shut down the pump. Refer to [Shut down the pump](#) on page 27.
2. Disconnect the pump from the electrical supply.
3. Install the protective covers over the inlet and outlet ports.
4. Store the pump in a clean and dry condition until necessary for use.
5. When necessary, prepare and install the pump. Refer to [Installation](#) on page 16.

## 10. Disposal



### **WARNING: CONTAMINATION HAZARD**

**Risk of toxic exposure and acid burns. Identify, contain and safely dispose of contaminated items.**

Dispose of the pump and any components or accessories safely. Obey all local and national safety and environmental requirements.

Our products are supported by a world-wide network of Service Centres. Each Service Centre offers a wide range of options including disposal. Refer to [Service](#) on page 29 for more information.

Dry pump system materials suitable for recycling include cast iron, steel, PTFE, stainless steel, aluminium, zinc alloy, nickel, mild steel, ABS and polyamide.

Take particular care with:

- Fluoroelastomers which may have decomposed as the result of being subjected to high temperatures
- Components which have been contaminated with dangerous process substances.

## 11. Accessories

Contact us for the accessories available to support your pump.

### 11.1 Digital operator

Digital operator allows the connection to the pump controller through the XLR connection socket on the interface control panel.

**Table 11** Digital operator

Description	Item number
Digital operator	D37520056

### 11.2 Electrical cables

Recommended cord sets for regional requirements.

**Table 12** Recommended cord sets

Description	Rating	Coupler type	Item number
Cord set assembly, UK	H05VV-F, 3 x 1.5 mm <sup>2</sup> , 300 V, 70 °C installed with a BS1363 UK plug with BS1362 13 A fuse to an IEC60320 style C19 with a maximum length of 2.5 m	Straight entry	A50505003
		Right-angled entry	A50505006
Cord set assembly, Europe	H05VV-F, 3 x 1.5 mm <sup>2</sup> , 300 V, 70 °C installed with a European Schuko VDE approved 16 A 250 V rated plug with dual earthing contact to an IEC60320 style C19 with a maximum length of 2.5 m	Straight entry	A50506003
		Right-angled entry	A50506006
Cord set assembly, USA/ Canada (200 - 240 V)	SJT, 3 x 14 AWG, 300 V, 90 °C, VW-1 installed with a NEMA 6-15P plug and IEC60320 C19 coupler with a maximum length of 3 m	NA	NA

