



GXS AAM/PAM Bracket kit

INSTRUCTION MANUAL

DESCRIPTION	Item number
GXS AAM/PAM Bracket kit	M58800041

Copyright notice

©Edwards Limited 2020. All rights reserved.

Trademark credit

Edwards and the Edwards logo are trademarks of Edwards Limited, Innovation Drive, Burgess Hill, West Sussex RH15 9TW.

Disclaimer

The content of this manual may change from time to time without notice. We accept no liability for any errors that may appear in this manual nor do we make any expressed or implied warranties regarding the content. As far as practical we have ensured that the products have been designed and constructed to be safe and without risks when properly installed and used in accordance with their operating instructions.

We accept no liability for loss of profit, loss of market or any other indirect or consequential loss whatsoever.

Product warranty and limit of liability are dealt with in our standard terms and conditions of sale or negotiated contract under which this document is supplied.

You must use this product as described in this manual. Read the manual before you install, operate, or maintain the product.

Contents

1. Safety and compliance.	4
1.1 Definition of Warnings and Cautions.	4
1.2 Safety symbols.	4
2. Installation.	6

1. Safety and compliance

1.1 Definition of Warnings and Cautions

NOTICE:



This manual meets our obligation to provide you with information. For safe operation from the start, read these instructions carefully before you install or commission the equipment.

Read all the safety instructions in this section and the rest of this manual carefully and make sure that you obey these instructions. The equipment must only be operated and maintained by trained personnel in the proper condition and as described in this instruction manual.

Obey local and state requirements and regulations. If you have any questions about safety, operation or maintenance of the device, please contact our nearest subsidiary.

Important safety information is highlighted as warning and caution instructions. Obey these instructions.



WARNING:

If you do not obey a warning, there is a risk of injury or death. Different symbols are used according to the type of hazard.



CAUTION:

If you do not obey a caution, there is a risk of minor injury, damage to equipment, related equipment or process.



NOTICE:

Information about properties or instructions for an action which, if ignored, will cause damage to the pump or the system.

We reserve the right to change the design and the stated data. The illustrations are not binding.

Keep the instructions for future use.

1.2 Safety symbols

The safety symbols on the products shows the areas where care and attention is necessary.

The safety symbols that follow are used on the product or in the product documentation.



Warning/Caution

A safety instruction which must be followed.

2. Installation

Refer to the GXS instruction manual (Publication number M58800880) for additional information.

- Make sure that the pump is set to off.

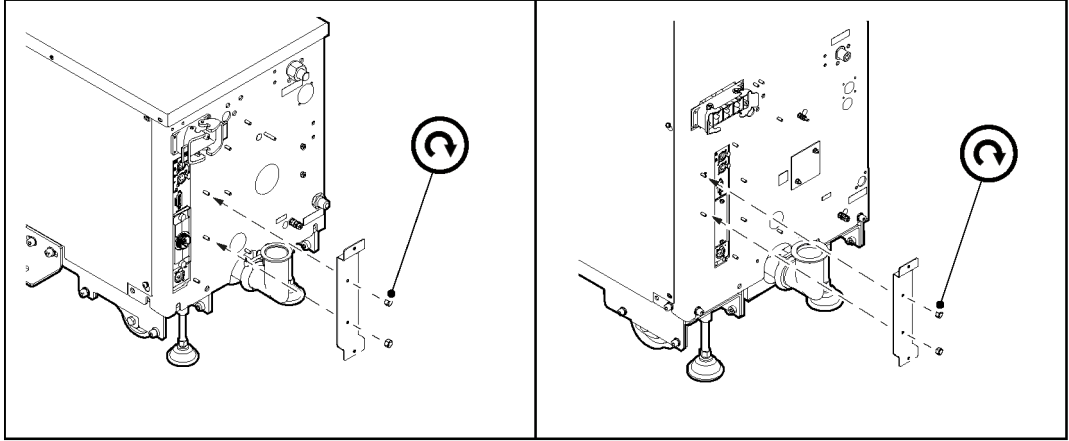

- Install the bracket with the nuts.
- Use the 1.5 Nm torque driver to tighten the screws.

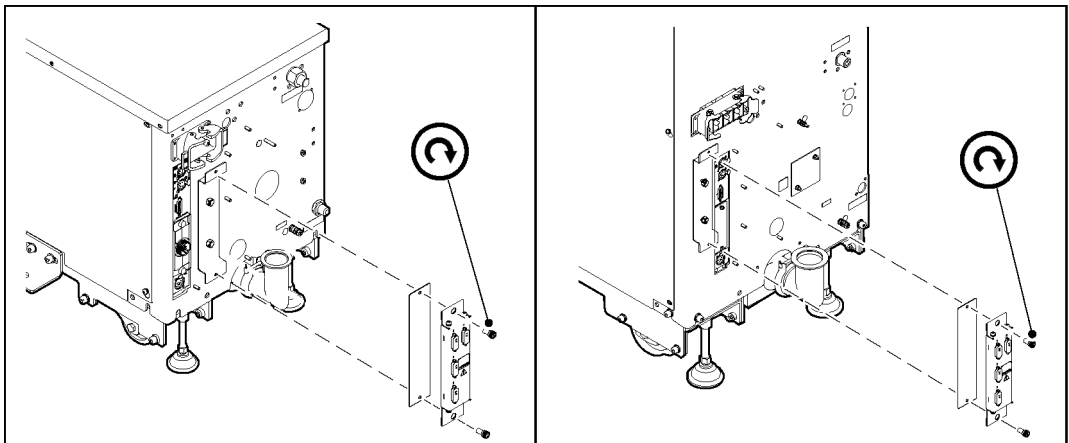

- Install the Passive Accessory Module (PAM) to the bracket with the plate.

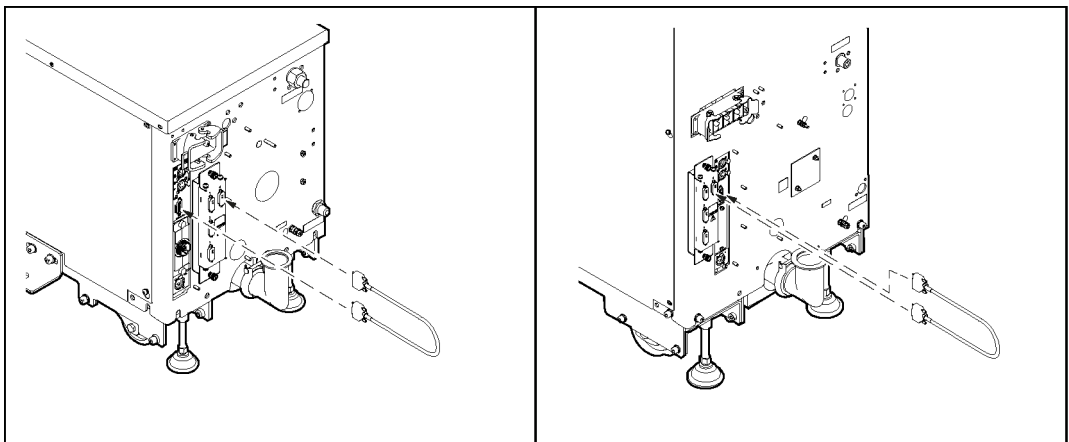

- Connect the AAM/PAM to the GXS 'Accessory' port, with the cable provided.



CAUTION: TRIP HAZARD

Risk of trip hazard. Make sure that all the wires are connected correctly to prevent a trip hazard.

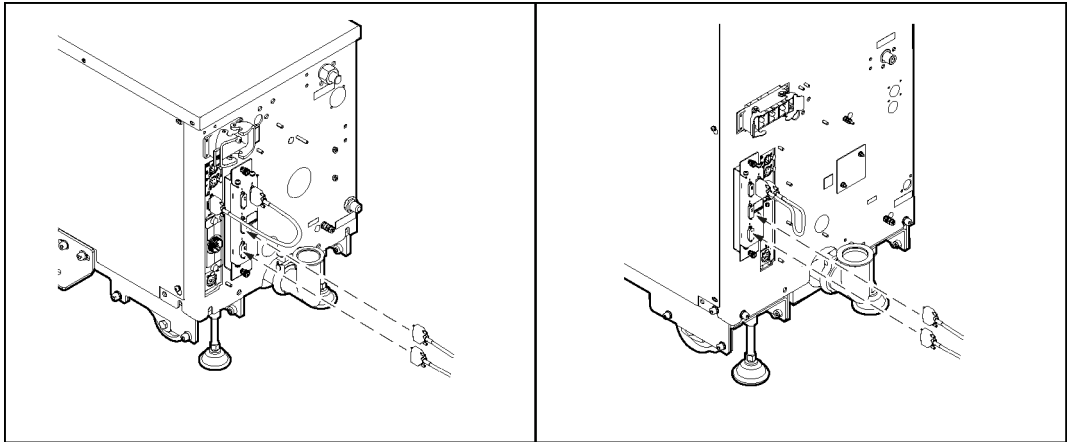

- Connect the accessory cable connectors to the AAM/PAM module.

